

Ecogenius Packaging System

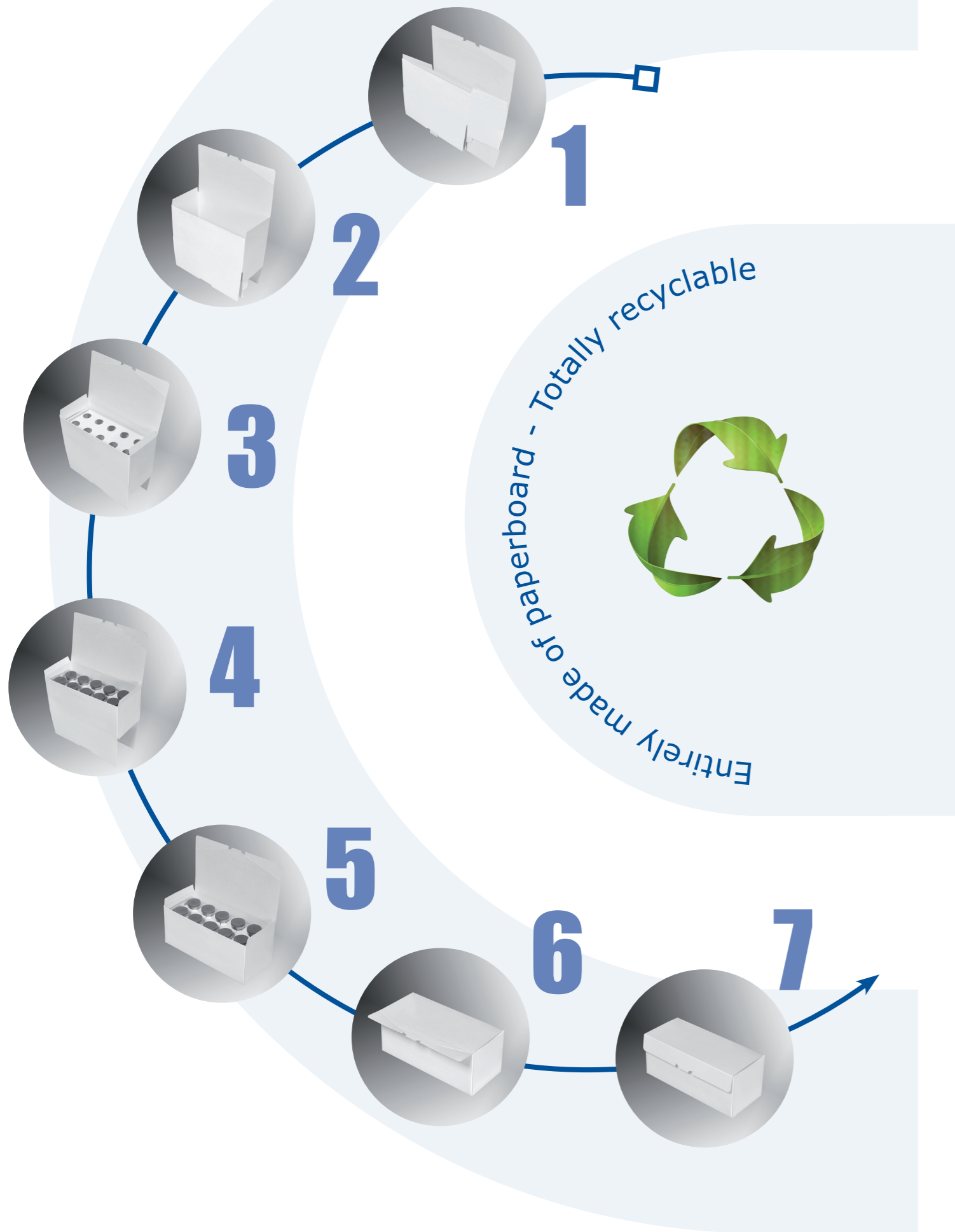

ECOGENIUS PACKAGING SYSTEM



+48 668 625 820
 info@atbgroup.pl
 www.atbgroup.pl



Via Emilia Ponente, 750
 48014 Castel Bolognese (Ra) - ITALY
 Tel. +39 0546 655911 - Fax +39 0546 655904
 E-mail: info@curti.com - Web: www.curti.com

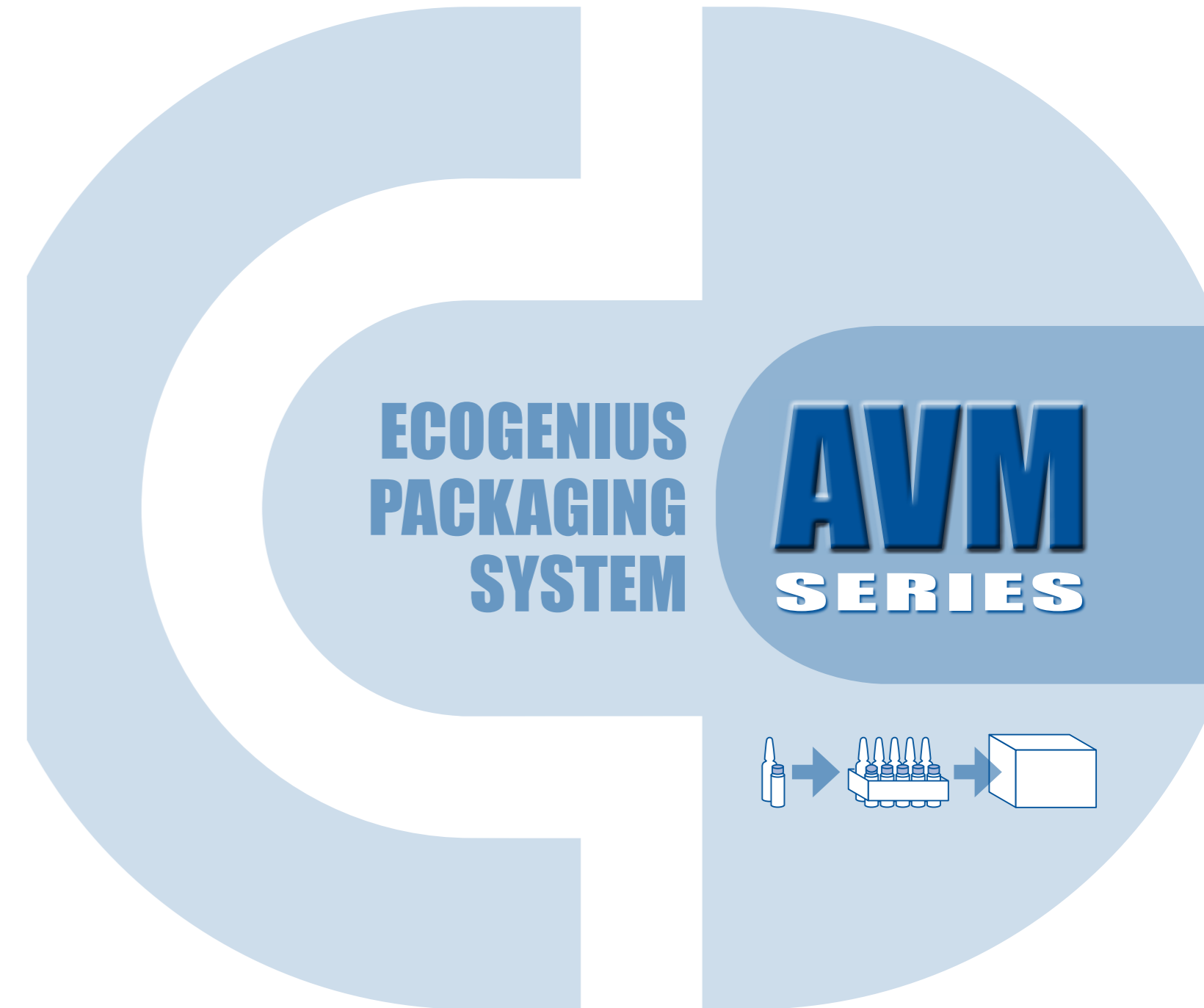

AVM SERIES

Alternate motion cartoning machine to package ampoules and vials



Mainly developed for pharmaceutical products, **AVM system** is one of the **cutting-edge** packaging solutions.

Designed to comply with the **strict pharma** industry regulations, it also pays a tribute to the **sustainability** of the production process by an innovative and **"green"** packaging solution.

Main Advantages of the ECOGENIUS Packaging System

- Lower cost of packaging, in comparison with traditional systems such as thermoformed tray, cardboard insert into a pre-glued carton or shaped cardboard insert glued on a flat blank
- Optimal protection of containers inside the carton
- Easy removal of containers from the carton
- Fully sustainable packaging solution (100% recyclable packaging)
- Less machinery in the complete packaging line (reduction of the overall capital investment, less personnel required for the line operation, less maintenance operations)

ECOGENIUS

AVM flex

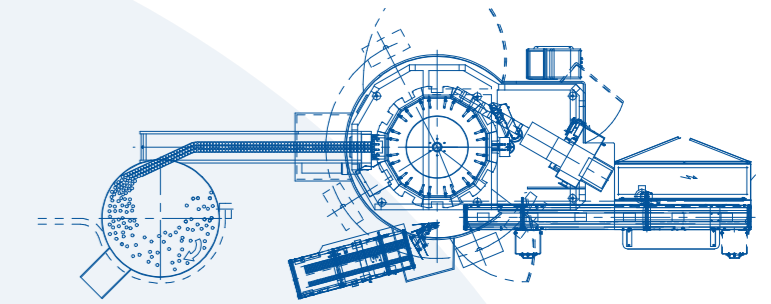
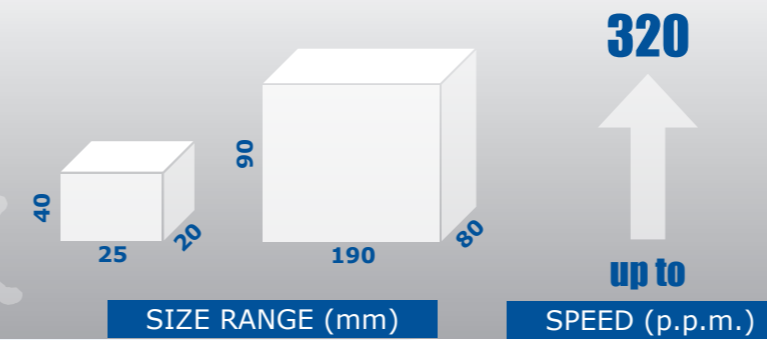

Single in-line feeding system by rotary table
Overall dimensions (mm): 6900 x 2900 x H2200

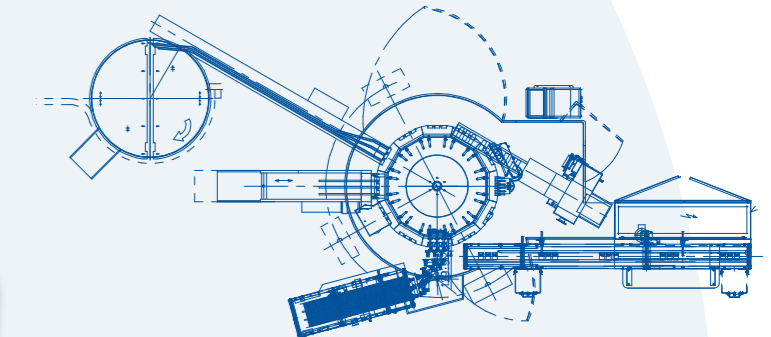

Double feeding system by tray and rotary table
Overall dimensions (mm): 7000 x 3300 x H2200

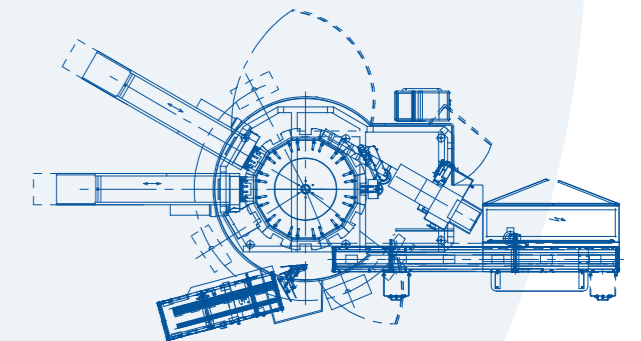

Double feeding system by trays
Overall dimensions (mm): 6000 x 3100 x H2200

Designed to match the speed of the upstream machinery, it enables to handle multiple cartons simultaneously, according to their size. The outlet speed is from 80 cartons/min for big carton sizes to 320 cartons/min (4x) for small sizes (single product packaging).

All the format parts feature quick changeover systems, designed to minimize the changeover time and granting a high flexibility of the machine.



Main Technical Features

- Made to work with pre-glued cartons
- Suitable to pack a wide range of containers such as vials, ampoules, cartridges in single or multiple combinations
- Product infeed by manual trays or automatically by the upstream machinery (with or without a rotary table as buffer)
- Tuck-in or hot melt carton closure
- Tamper evident labelling, in-line printing of variable data or 2D codes as well as vision and inspection systems for product security can be part of the machine equipment
- Complete machine changeover in 25 min by quick changeover systems developed for all the format parts

Weight	kg 6500
Air consumption	250 NI/min @ 6 bars
Installed power	27 kW
Absorbed Power	13 kW
Noise level	< 80 dB

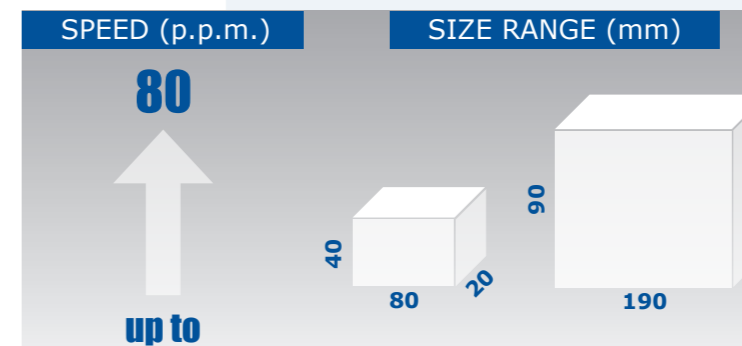

AVM